

RTD SAMPLER

OPERATOR'S MANUAL

1 Product Overview 1.1
 Specifications 1.1

2 Installation & Operation 2.1
 Unpacking the RTD Sampler 2.1
 Main Board and Expansion Board 2.1
 Mounting the RTD Sampler 2.2
 Conduit and Cabling 2.2
 Power Wiring 2.2
 RTD Sensor Wiring 2.2

Warranty Back Cover

Specifications

Temperature Measurement Range

Range: -50°C to 500°C, -58°F to 932°F
 Absolute Accuracy: ±2.5°C, ±4.5°F
 Repeatability: ±1°C, ±1.8°F
 RTD: 100 ohm platinum, 3-wire 10 ohms maximum lead resistance

Model

Configuration SAM-RTDxx-120V-y
 xx=10: 10 RTDs; xx=20: 20 RTDs.
 y=R: RS485; y=M: Wireless.

Control Power

Power Requirements SAM-RTDxx-120V-y: 120VAC, 10VA
 Line Frequency 50 or 60Hz
 Protection Protected by non-replaceable 2A, time lag, 350 VAC fuse
 MOV transient protection and RC snubber

Communication Media

RS485 Cable Transmit RTD measurements via RS485 Cable (Figure 1)
 Wireless RF Modem Transmit RTD measurements via Wireless RF Modems (Figure 2)

User Interface

LED Power on, RTD OK, Transmit, Receive
 RS485 Port Accessible to Laptop, PC

Environment

Approvals: CSA
 Class I, Div.2, Groups A,B,C,D
 Class I, Zone 2, Ex nA IIC, AEx nA IIC
 Operating Range: -40°C to +50°C
 Conformal Coating: Boards conformal coated for hostile environments. Altitude: 0-2000m

Enclosure

Type: Nema-4 steel
 Size: 10"Hx8"Wx4"D
 Features: Quick release latches to open door
 One 0.875" conduit knockout for power wiring, two 1.093" conduit knocks for RTD wiring, one 0.75" conduit knock for RS485 cable or Antenna.

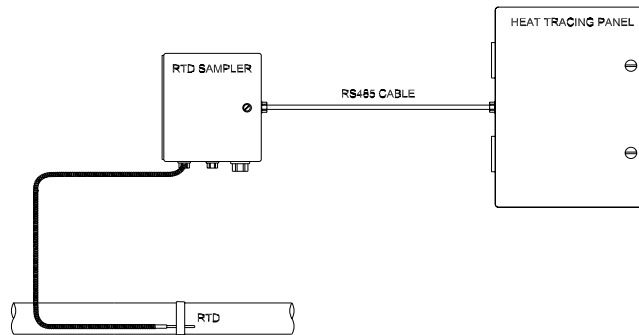

Figure 1. Transmit RTD Measurement via RS485 Cable

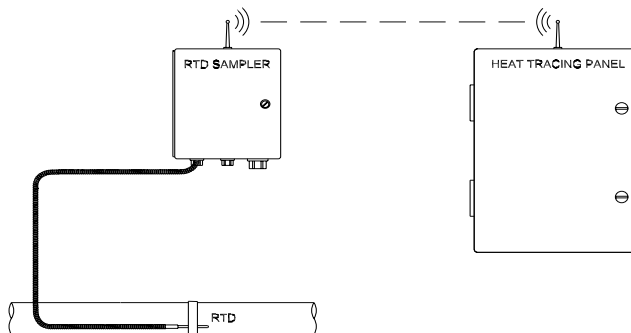

Figure 2. Transmit RTD Measurement via Wireless RF Modem

Unpacking the RTD Sampler

Check the shipping cartons for damage, or other signs of rough handling or abuse. If damaged, notify the shipping carrier at once.

Carefully remove the RTD Sampler from the shipping box. Inspect enclosure surface for shipping damage and check electronics for loose wiring or damage. Report any damage to the carrier at once.

Main Board and Expansion Board

See *Figure 2 RTD Sampler Main Board and Expansion Board Layout* to locate the following:

Switches

- **S1-4** Sampler Address: S1-4 consists of 4 switches. They are S1, S2, S3, and S4. These 4 switches generate a Sampler Address in a range of 0-15. The exact value of this Sampler Address equals the sum of the contributions by each switch. If a switch is in **OFF** position, its contribution is zero. If it is in **ON** position, its contribution equals the value labeled on the board.

Ex. 1: If all 4 switches are in the **ON** position,
Sampler Address = 1 + 2 + 4 + 8 = 15.

Ex. 2: If only switches S1 and S4 are in the **ON** position,
Sampler Address = 1 + 0 + 0 + 8 = 9.

- **RTD20/10** Sampler Type selector: If the switch is on RTD20 side, the RTD Sampler will measure up to 20

RTD temperatures. If it is on RTD10 side, the RTD Sampler will measure up to 10 RTD temperatures.

Terminals

- **T1** Communication Port.
Connect T1 to heat tracing control modules through RS485 cable.
- **T2** +12VDC Power Output.
- **T3-T12** RTD1-RTD10: 3-wire RTD input.
- **T13** 120VAC Power Input: L-Live, N-Neutral, G-Ground.
- **T14-T23** RTD11-RTD20: 3-wire RTD input.

RTD11-RTD20 are located on the expansion board which is mounted on the main board through 4 screws. For SAM-RTD10-120V model, the expansion board is not included.

Status Lights:

- **L1** PWR ON: Light is on when AC power is present.
- **L2** RTD OK: Light is on when all RTDs are OK.
- **L3** RECEIVE: Light is on when sampler is receiving communication data.
- **L4** TRANSMIT: Light is on when sampler is transmitting communication data.

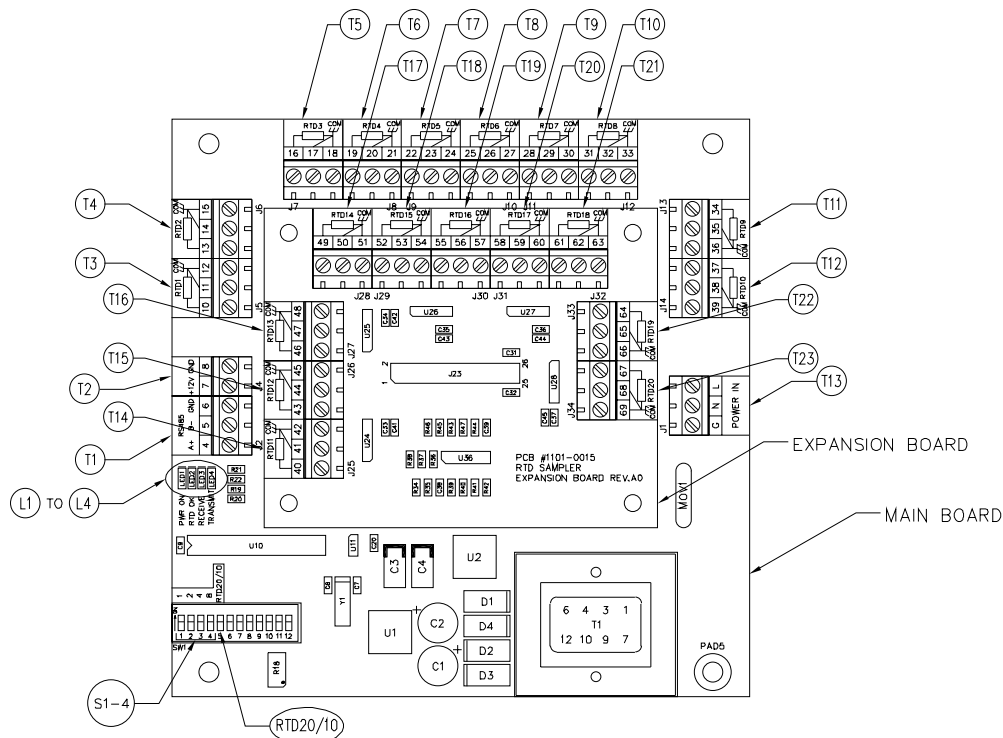

Figure 2. RTD Sampler Main Board and Expansion Board Layout

Mounting the RTD Sampler

Mount the control panel with Unistrut brackets using 5/16" bolts. Mounting dimensions are shown in *Figure 3*.

Conduit and Cabling

RTD Sampler comes with two 1.093" & one 0.875" conduit knockouts located on the bottom of the enclosure, and one 0.75" conduit knockout on the right of the enclosure. NEMA-4X rated conduit hubs with appropriate sizes should be used to maintain the cabling through the conduits a watertight seal. Unused knockouts should be sealed using NEMA-4X rated seals.

Power Wiring

The power input terminals supply power to the RTD Sampler. Size the power input wires appropriately to the RTD Sampler's power requirement, 120VAC 0.5A. Connect power wires to input terminals G, N, & L. See *Figure 4 Typical Wiring Diagram*.



The supply voltage must be 120VAC for both SAM-RTD10-120V and SAM-RTD20-120V.

RTD Sensor Wiring

RTD sensors should be 3-wire, 100 ohm, platinum to DIN standard 43760. The total circuit resistance per conductor from the RTD to the RTD Sampler must be less than 10 ohm. Exceeding this resistance will result in a non-linear temperature measurement. Beldon cable 8770 or equivalent allows RTDs to be placed up to 1,000 feet from the control panel. Complete all RTD wiring according to *Figure 4 Typical Wiring Diagram*.

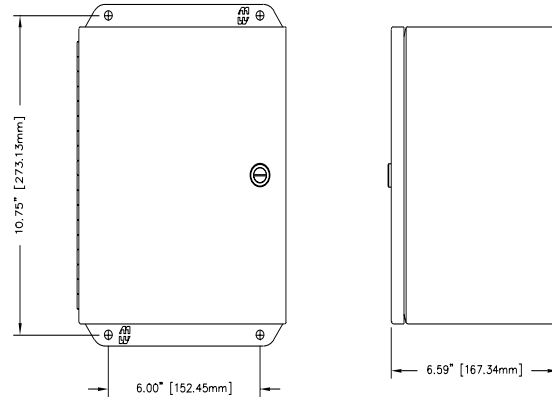

Figure 3. Enclosure and Mounting Dimensions

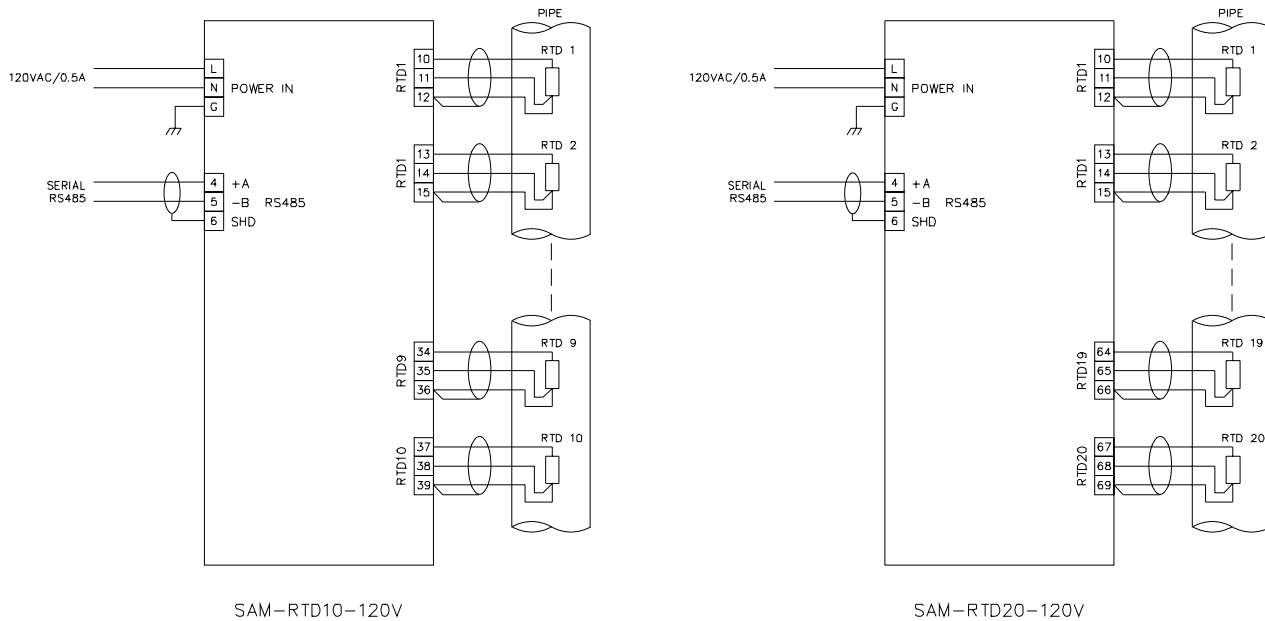

Figure 4. Typical Wiring Diagram

Warranty

The manufacturer warrants each control that it manufactures to be free from defective material or workmanship for a period of 12 months from date of purchase.

Under this warranty, the obligation of the manufacturer is limited to repairing or replacing the defective control at its option, when returned to the manufacturer's factory with shipping charges prepaid.

If failure has been caused by misuse, incorrect application or alteration of the control, this warranty will be void.

UNLESS SPECIFICALLY PROVIDED FOR IN WRITING IN THIS WARRANTY, EACH CONTROL IS PROVIDED WITHOUT ANY WARRANTY OF ANY KIND EITHER EXPRESSED OR IMPLIED. IN PARTICULAR, WITHOUT LIMITING THE GENERALITY OF THE FOREGOING, THE FOLLOWING IMPLIED WARRANTIES AND CONDITIONS ARE EXPRESSLY DISCLAIMED:

- a). ANY IMPLIED WARRANTY OR CONDITION THAT THE CONTROL WILL MEET YOUR REQUIREMENTS.**
- b). ANY IMPLIED WARRANTY OR CONDITION THAT THE OPERATION OF THE CONTROL WILL BE UNINTERRUPTED OR ERROR FREE; AND**
- c). ANY IMPLIED WARRANTY OR CONDITION OF MERCHANTABILITY OR FITNESS FOR A PARTICULAR PURPOSE.**

The user shall be made aware that if the equipment is used in a manner not specified by the manufacturer, the protection provided by the equipment may be impaired.

RTD SAMPLER